

LIMN

Limn is a proprietary software written by David Wiseman of David Wiseman (Pty) Ltd, using Microsoft Excel as the platform.

OMC use Limn for:

- Equipment selection confirmation for Crushing and Screening Circuits.
- Mass and Water balances.
- Crushing and Screening Circuit Flowsheet design studies for new circuits.

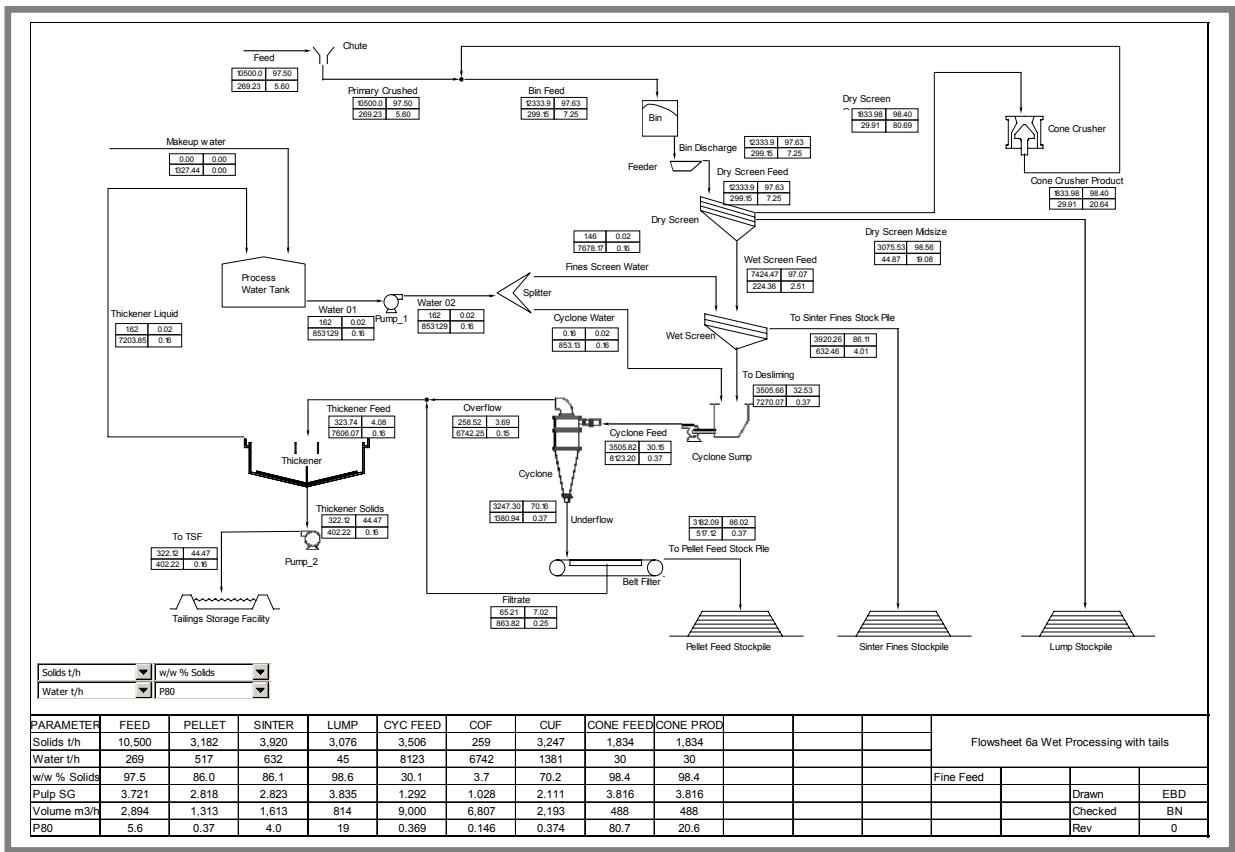

Typical Limn Flowsheet